

# The Programming Language Oberon-2

H. Mössenböck, N. Wirth  
 Institut für Computersysteme, ETH Zürich  
 October 1993

## 1. Introduction

Oberon-2 is a general-purpose language in the tradition of Oberon and Modula-2. Its most important features are block structure, modularity, separate compilation, static typing with strong type checking (also across module boundaries), and type extension with type-bound procedures.

Type extension makes Oberon-2 an object-oriented language. An object is a variable of an abstract data type consisting of private data (its state) and procedures that operate on this data. Abstract data types are declared as extensible records. Oberon-2 covers most terms of object-oriented languages by the established vocabulary of imperative languages in order to minimize the number of notions for similar concepts.

This report is not intended as a programmer's tutorial. It is intentionally kept concise. Its function is to serve as a reference for programmers, implementors, and manual writers. What remains unsaid is mostly left so intentionally, either because it can be derived from stated rules of the language, or because it would require to commit the definition when a general commitment appears as unwise.

Appendix A defines some terms that are used to express the type checking rules of Oberon-2. Where they appear in the text, they are written in italics to indicate their special meaning (e.g. the *same* type).

## 2. Syntax

An extended Backus-Naur Formalism (EBNF) is used to describe the syntax of Oberon-2: Alternatives are separated by |. Brackets [ and ] denote optionality of the enclosed expression, and braces { and } denote its repetition (possibly 0 times). Non-terminal symbols start with an upper-case letter (e.g. Statement). Terminal symbols either start with a lower-case letter (e.g. ident), or are written all in upper-case letters (e.g. BEGIN), or are denoted by strings (e.g. ":=").

## 3. Vocabulary and Representation

The representation of (terminal) symbols in terms of characters is defined using the ASCII set. Symbols are identifiers, numbers, strings, operators, and delimiters. The following lexical rules must be observed: Blanks and line breaks must not occur within symbols (except in comments, and blanks in strings). They are ignored unless they are essential to separate two consecutive symbols. Capital and lower-case letters are considered as distinct.

1. *Identifiers* are sequences of letters and digits. The first character must be a letter.

ident = letter {letter | digit}.

Examples: x Scan Oberon2 GetSymbol firstLetter

2. *Numbers* are (unsigned) integer or real constants. The type of an integer constant is the minimal type to which the constant value belongs (see 6.1). If the constant is specified with the suffix H, the representation is hexadecimal otherwise the representation is decimal.

A real number always contains a decimal point. Optionally it may also contain a decimal scale factor. The letter E (or D) means "times ten to the power of". A real number is of type REAL, unless it has a scale factor containing the letter D. In this case it is of type LONGREAL.

number	= integer   real.
integer	= digit {digit}   digit {hexDigit} "H".
real	= digit {digit} "." {digit} [ScaleFactor].
ScaleFactor	= ("E"   "D") ["+"   "-"] digit {digit}.
hexDigit	= digit   "A"   "B"   "C"   "D"   "E"   "F".
digit	= "0"   "1"   "2"   "3"   "4"   "5"   "6"   "7"   "8"   "9".

Examples:

1991	INTEGER	1991
0DH	SHORTINT	13
12.3	REAL	12.3
4.567E8	REAL	456700000
0.57712566D-6	LONGREAL	0.00000057712566

3. *Character* constants are denoted by the ordinal number of the character in hexadecimal notation followed by the letter X.

character = digit {hexDigit} "X".

4. *Strings* are sequences of characters enclosed in single (') or double (") quote marks. The opening quote must be the same as the closing quote and must not occur within the string. The number of characters in a string is called its *length*. A string of length 1 can be used wherever a character constant is allowed and vice versa.

```
string = ' ' {char} ' ' | " " {char} " " .
```

Examples: "Oberon-2" "Don't worry!" "x"

5. *Operators* and *delimiters* are the special characters, character pairs, or reserved words listed below. The reserved words consist exclusively of capital letters and cannot be used as identifiers.

+	:=	ARRAY	IMPORT	RETURN
-	^	BEGIN	IN	THEN
*	=	BY	IS	TO
/	#	CASE	LOOP	TYPE
~	<	CONST	MOD	UNTIL
&	>	DIV	MODULE	VAR
.	<=	DO	NIL	WHILE
,	>=	ELSE	OF	WITH
:	..	ELSIF	OR	
	:	END	POINTER	
(	)	EXIT	PROCEDURE	
[	]	FOR	RECORD	
{	}	IF	REPEAT	

6. *Comments* may be inserted between any two symbols in a program. They are arbitrary character sequences opened by the bracket (\*) and closed by \*). Comments may be nested. They do not affect the meaning of a program.

#### 4. Declarations and scope rules

Every identifier occurring in a program must be introduced by a declaration, unless it is a predeclared identifier. Declarations also specify certain permanent properties of an object, such as whether it is a constant, a type, a variable, or a procedure. The identifier is then used to refer to the associated object.

The *scope* of an object  $x$  extends textually from the point of its declaration to the end of the block (module, procedure, or record) to which the declaration belongs and hence to which the object is *local*. It excludes the scopes of equally named objects which are declared in nested blocks. The scope rules are:

1. No identifier may denote more than one object within a given scope (i.e. no identifier may be declared twice in a block);
2. An object may only be referenced within its scope;
3. A type  $T$  of the form POINTER TO  $T1$  (see 6.4) can be declared at a point where  $T1$  is still unknown. The declaration of  $T1$  must follow in the same block to which  $T$  is local;
4. Identifiers denoting record fields (see 6.3) or type-bound procedures (see 10.2) are valid in record designators only.

An identifier declared in a module block may be followed by an export mark ("\*" or "-") in its declaration to indicate that it is exported. An identifier  $x$  exported by a module  $M$  may be used in other modules, if they import  $M$  (see Ch.11). The identifier is then denoted as  $M.x$  in these modules and is called a *qualified identifier*. Identifiers marked with "-" in their declaration are *read-only* in importing modules.

```
Qualident    = [ident "."] ident.
IdentDef     = ident ["*" | "-" ].
```

The following identifiers are predeclared; their meaning is defined in the indicated sections:

ABS	(10.3)	LEN	(10.3)
ASH	(10.3)	LONG	(10.3)
BOOLEAN	(6.1)	LONGINT	(6.1)
CAP	(10.3)	LONGREAL	(6.1)
CHAR	(6.1)	MAX	(10.3)
CHR	(10.3)	MIN	(10.3)
COPY	(10.3)	NEW	(10.3)
DEC	(10.3)	ODD	(10.3)
ENTIER	(10.3)	ORD	(10.3)
EXCL	(10.3)	REAL	(6.1)
FALSE	(6.1)	SET	(6.1)
HALT	(10.3)	SHORT	(10.3)
INC	(10.3)	SHORTINT	(6.1)
INCL	(10.3)	SIZE	(10.3)
INTEGER	(6.1)	TRUE	(6.1)

## 5. Constant declarations

A constant declaration associates an identifier with a constant value.

```
ConstantDeclaration = IdentDef "=" ConstExpression.
ConstExpression    = Expression.
```

A constant expression is an expression that can be evaluated by a mere textual scan without actually executing the program. Its operands are constants (Ch.8) or predeclared functions (Ch.10.3) that can be evaluated at compile time. Examples of constant declarations are:

```
N = 100
limit = 2*N - 1
fullSet = {MIN(SET) .. MAX(SET)}
```

## 6. Type declarations

A data type determines the set of values which variables of that type may assume, and the operators that are applicable. A type declaration associates an identifier with a type. In the case of structured types (arrays and records) it also defines the structure of variables of this type. A structured type cannot contain itself.

```
TypeDeclaration = IdentDef "=" Type.
Type            = Qualident | ArrayType | RecordType | PointerType | ProcedureType.
```

Examples:

```
Table = ARRAY N OF REAL
Tree = POINTER TO Node
Node = RECORD
  key : INTEGER;
  left, right: Tree
END
CenterTree = POINTER TO CenterNode
CenterNode = RECORD (Node)
  width: INTEGER;
  subnode: Tree
END
Function = PROCEDURE(x: INTEGER): INTEGER
```

### 6.1 Basic types

The basic types are denoted by predeclared identifiers. The associated operators are defined in 8.2 and the predeclared function procedures in 10.3. The values of the given basic types are the following:

1. BOOLEAN the truth values TRUE and FALSE
2. CHAR the characters of the extended ASCII set (0X .. 0FFX)
3. SHORTINT the integers between MIN(SHORTINT) and MAX(SHORTINT)
4. INTEGER the integers between MIN(INTEGER) and MAX(INTEGER)
5. LONGINT the integers between MIN(LONGINT) and MAX(LONGINT)
6. REAL the real numbers between MIN(REAL) and MAX(REAL)
7. LONGREAL the real numbers between MIN(LONGREAL) and MAX(LONGREAL)
8. SET the sets of integers between 0 and MAX(SET)

Types 3 to 5 are *integer types*, types 6 and 7 are *real types*, and together they are called *numeric types*. They form a hierarchy; the larger type *includes* (the values of) the smaller type:

```
LONGREAL >= REAL >= LONGINT >= INTEGER >= SHORTINT
```

### 6.2 Array types

An array is a structure consisting of a number of elements which are all of the same type, called the *element type*. The number of elements of an array is called its *length*. The elements of the array are designated by indices, which are integers between 0 and the length minus 1.

```
ArrayType = ARRAY [Length {"," Length}] OF Type.
Length = ConstExpression.
```

A type of the form

```
ARRAY L0, L1, ..., Ln OF T
```

is understood as an abbreviation of

```

ARRAY L0 OF
  ARRAY L1 OF
  ...
  ARRAY Ln OF T

```

Arrays declared without length are called *open arrays*. They are restricted to pointer base types (see 6.4), element types of open array types, and formal parameter types (see 10.1). Examples:

```

ARRAY 10, N OF INTEGER
ARRAY OF CHAR

```

### 6.3 Record types

A record type is a structure consisting of a fixed number of elements, called *fields*, with possibly different types. The record type declaration specifies the name and type of each field. The scope of the field identifiers extends from the point of their declaration to the end of the record type, but they are also visible within designators referring to elements of record variables (see 8.1). If a record type is exported, field identifiers that are to be visible outside the declaring module must be marked. They are called *public fields*; unmarked elements are called *private fields*.

```

RecordType   = RECORD ["("BaseType)"] FieldList {";" FieldList} END.
BaseType     = Qualident.
FieldList    = [IdentList ":" Type ].

```

Record types are extensible, i.e. a record type can be declared as an extension of another record type. In the example

```

T0 = RECORD x: INTEGER END
T1 = RECORD (T0) y: REAL END

```

*T1* is a (direct) *extension* of *T0* and *T0* is the (direct) *base type* of *T1* (see App. A). An extended type *T1* consists of the fields of its base type and of the fields which are declared in *T1*. All identifiers declared in the extended record must be different from the identifiers declared in its base type record(s).

Examples of record type declarations:

```

RECORD
  day, month, year: INTEGER
END

RECORD
  name, firstname: ARRAY 32 OF CHAR;
  age: INTEGER;
  salary: REAL
END

```

### 6.4 Pointer types

Variables of a pointer type *P* assume as values pointers to variables of some type *T*. *T* is called the pointer base type of *P* and must be a record or array type. Pointer types adopt the extension relation of their pointer base types: if a type *T1* is an extension of *T*, and *P1* is of type POINTER TO *T1*, then *P1* is also an extension of *P*.

```

PointerType = POINTER TO Type.

```

If *p* is a variable of type *P* = POINTER TO *T*, a call of the predeclared procedure *NEW(p)* (see 10.3) allocates a variable of type *T* in free storage. If *T* is a record type or an array type with fixed length, the allocation has to be done with *NEW(p)*; if *T* is an *n*-dimensional open array type the allocation has to be done with *NEW(p, e0, ..., en-1)* where *T* is allocated with lengths given by the expressions *e0, ..., en-1*. In either case a pointer to the allocated variable is assigned to *p*. *p* is of type *P*. The *referenced* variable *p*<sup>^</sup> (pronounced as *p*-referenced) is of type *T*. Any pointer variable may assume the value NIL, which points to no variable at all.

### 6.5 Procedure types

Variables of a procedure type *T* have a procedure (or NIL) as value. If a procedure *P* is assigned to a variable of type *T*, the formal parameter lists (see Ch. 10.1) of *P* and *T* must *match* (see App. A). *P* must not be a predeclared or type-bound procedure nor may it be local to another procedure.

```

ProcedureType = PROCEDURE [FormalParameters].

```

## 7. Variable declarations

Variable declarations introduce variables by defining an identifier and a data type for them.

VariableDeclaration = IdentList ":" Type.

Record and pointer variables have both a *static type* (the type with which they are declared – simply called their type) and a *dynamic type* (the type of their value at run time). For pointers and variable parameters of record type the dynamic type may be an extension of their static type. The static type determines which fields of a record are accessible. The dynamic type is used to call type-bound procedures (see 10.2).

Examples of variable declarations (refer to examples in Ch. 6):

```
i, j, k: INTEGER
x, y: REAL
p, q: BOOLEAN
s: SET
F: Function
a: ARRAY 100 OF REAL
w: ARRAY 16 OF RECORD
    name: ARRAY 32 OF CHAR;
    count: INTEGER
END
t, c: Tree
```

## 8. Expressions

Expressions are constructs denoting rules of computation whereby constants and current values of variables are combined to compute other values by the application of operators and function procedures. Expressions consist of operands and operators. Parentheses may be used to express specific associations of operators and operands.

### 8.1 Operands

With the exception of set constructors and literal constants (numbers, character constants, or strings), operands are denoted by *designators*. A designator consists of an identifier referring to a constant, variable, or procedure. This identifier may possibly be qualified by a module identifier (see Ch. 4 and 11) and may be followed by *selectors* if the designated object is an element of a structure.

```
Designator      = Qualident {"." ident | "[" ExpressionList "]" | "^" | "(" Qualident ")"}
ExpressionList = Expression {"," Expression}.
```

If  $a$  designates an array, then  $a[e]$  denotes that element of  $a$  whose index is the current value of the expression  $e$ . The type of  $e$  must be an integer type. A designator of the form  $a[e_0, e_1, \dots, e_n]$  stands for  $a[e_0][e_1] \dots [e_n]$ . If  $r$  designates a record, then  $r.f$  denotes the field  $f$  of  $r$  or the procedure  $f$  bound to the dynamic type of  $r$  (Ch. 10.2). If  $p$  designates a pointer,  $p^\wedge$  denotes the variable which is referenced by  $p$ . The designators  $p^\wedge.f$  and  $p^\wedge[e]$  may be abbreviated as  $p.f$  and  $p[e]$ , i.e. record and array selectors imply dereferencing. If  $a$  or  $r$  are read-only, then also  $a[e]$  and  $r.f$  are read-only.

A *type guard*  $v(T)$  asserts that the dynamic type of  $v$  is  $T$  (or an extension of  $T$ ), i.e. program execution is aborted, if the dynamic type of  $v$  is not  $T$  (or an extension of  $T$ ). Within the designator,  $v$  is then regarded as having the static type  $T$ . The guard is applicable, if

1.  $v$  is a variable parameter of record type or  $v$  is a pointer, and if
2.  $T$  is an extension of the static type of  $v$

If the designated object is a constant or a variable, then the designator refers to its current value. If it is a procedure, the designator refers to that procedure unless it is followed by a (possibly empty) parameter list in which case it implies an activation of that procedure and stands for the value resulting from its execution. The actual parameters must correspond to the formal parameters as in proper procedure calls (see 10.1).

Examples of designators (refer to examples in Ch.7):

```
i                (INTEGER)
a[i]             (REAL)
w[3].name[i]    (CHAR)
t.left.right    (Tree)
t(CenterTree).subnode (Tree)
```

### 8.2 Operators

Four classes of operators with different precedences (binding strengths) are syntactically distinguished in expressions. The operator  $\sim$  has the highest precedence, followed by multiplication operators, addition operators, and relations. Operators of the same precedence associate from left to right. For example,  $x-y-z$  stands for  $(x-y)-z$ .

Expression	= SimpleExpression [Relation SimpleExpression].
SimpleExpression	= ["+"   "-"] Term {AddOperator Term}.
Term	= Factor {MulOperator Factor}.
Factor	= Designator [ActualParameters]   number   character   string   NIL   Set   "(" Expression ")"   "~" Factor.
Set	= "{" [Element {" Element"}] }".
Element	= Expression ["." Expression].
ActualParameters	= "(" [ExpressionList] )".
Relation	= "="   "#"   "<"   "<="   ">"   ">="   IN   IS.
AddOperator	= "+"   "-"   OR.
MulOperator	= "*"   "/"   DIV   MOD   "&".

The available operators are listed in the following tables. Some operators are applicable to operands of various types, denoting different operations. In these cases, the actual operation is identified by the type of the operands. The operands must be *expression compatible* with respect to the operator (see App. A).

### 8.2.1 Logical operators

OR	logical disjunction	p OR q	"if p then TRUE, else q"
&	logical conjunction	p & q	"if p then q, else FALSE"
~	negation	~ p	"not p"

These operators apply to BOOLEAN operands and yield a BOOLEAN result.

### 8.2.2 Arithmetic operators

+	sum
-	difference
*	product
/	real quotient
DIV	integer quotient
MOD	modulus

The operators +, -, \*, and / apply to operands of numeric types. The type of the result is the type of that operand which includes the type of the other operand, except for division (/), where the result is the smallest real type which includes both operand types. When used as monadic operators, - denotes sign inversion and + denotes the identity operation. The operators DIV and MOD apply to integer operands only. They are related by the following formulas defined for any x and positive divisors y:

$$x = (x \text{ DIV } y) * y + (x \text{ MOD } y)$$

$$0 \leq (x \text{ MOD } y) < y$$

Examples:

x	y	x DIV y	x MOD y
5	3	1	2
-5	3	-2	1

### 8.2.3 Set Operators

+	union
-	difference ( $x - y = x * (-y)$ )
*	intersection
/	symmetric set difference ( $x / y = (x - y) + (y - x)$ )

Set operators apply to operands of type SET and yield a result of type SET. The monadic minus sign denotes the complement of x, i.e. -x denotes the set of integers between 0 and MAX(SET) which are not elements of x. Set operators are not associative ((a+b)-c # a+(b-c)).

A set constructor defines the value of a set by listing its elements between curly brackets. The elements must be integers in the range 0..MAX(SET). A range a..b denotes all integers in the interval [a, b].

### 8.2.4 Relations

=	equal
#	unequal
<	less
<=	less or equal
>	greater
>=	greater or equal
IN	set membership
IS	type test

Relations yield a BOOLEAN result. The relations =, #, <, <=, >, and >= apply to the numeric types, CHAR, strings, and character arrays containing 0X as a terminator. The relations = and # also apply to BOOLEAN and SET, as well as to pointer and procedure types (including the value NIL). x IN s stands for "x is an element of s". x must be of

an integer type, and  $s$  of type SET.  $v$  IS  $T$  stands for "the dynamic type of  $v$  is  $T$  (or an extension of  $T$ )" and is called a *type test*. It is applicable if

1.  $v$  is a variable parameter of record type or  $v$  is a pointer, and if
2.  $T$  is an extension of the static type of  $v$

Examples of expressions (refer to examples in Ch.7):

1991	INTEGER
i DIV 3	INTEGER
~p OR q	BOOLEAN
(i+j) * (i-j)	INTEGER
s - {8, 9, 13}	SET
i + x	REAL
a[i+j] * a[i-j]	REAL
(0<=i) & (i<100)	BOOLEAN
t.key = 0	BOOLEAN
k IN {i..j-1}	BOOLEAN
w[i].name <= "John"	BOOLEAN
t IS CenterTree	BOOLEAN

## 9. Statements

Statements denote actions. There are elementary and structured statements. Elementary statements are not composed of any parts that are themselves statements. They are the assignment, the procedure call, the return, and the exit statement. Structured statements are composed of parts that are themselves statements. They are used to express sequencing and conditional, selective, and repetitive execution. A statement may also be empty, in which case it denotes no action. The empty statement is included in order to relax punctuation rules in statement sequences.

Statement =  
 [ Assignment | ProcedureCall | IfStatement | CaseStatement | WhileStatement | RepeatStatement |  
 ForStatement | LoopStatement | WithStatement | EXIT | RETURN [Expression] ].

### 9.1 Assignments

Assignments replace the current value of a variable by a new value specified by an expression. The expression must be *assignment compatible* with the variable (see App. A). The assignment operator is written as ":= " and pronounced as *becomes*.

Assignment = Designator " := " Expression.

If an expression  $e$  of type  $T_e$  is assigned to a variable  $v$  of type  $T_v$ , the following happens:

1. if  $T_v$  and  $T_e$  are record types, only those fields of  $T_e$  are assigned which also belong to  $T_v$  (*projection*); the dynamic type of  $v$  must be the *same* as the static type of  $v$  and is not changed by the assignment;
2. if  $T_v$  and  $T_e$  are pointer types, the dynamic type of  $v$  becomes the dynamic type of  $e$ ;
3. if  $T_v$  is ARRAY  $n$  OF CHAR and  $e$  is a string of length  $m < n$ ,  $v[i]$  becomes  $e_i$  for  $i = 0..m-1$  and  $v[m]$  becomes 0X.

Examples of assignments (refer to examples in Ch.7):

```
i := 0
p := i = j
x := i + 1
k := log2(i+j)
F := log2 (* see 10.1 *)
s := {2, 3, 5, 7, 11, 13}
a[i] := (x+y) * (x-y)
t.key := i
w[i+1].name := "John"
t := c
```

### 9.2 Procedure calls

A procedure call activates a procedure. It may contain a list of actual parameters which replace the corresponding formal parameters defined in the procedure declaration (see Ch. 10). The correspondence is established by the positions of the parameters in the actual and formal parameter lists. There are two kinds of parameters: *variable* and *value parameters*.

If a formal parameter is a variable parameter, the corresponding actual parameter must be a designator denoting a variable. If it denotes an element of a structured variable, the component selectors are evaluated when the formal/actual parameter substitution takes place, i.e. before the execution of the procedure. If a formal parameter is a value parameter, the corresponding actual parameter must be an expression. This expression is evaluated before the

procedure activation, and the resulting value is assigned to the formal parameter (see also 10.1).

ProcedureCall = Designator [ActualParameters].

Examples:

```
WriteInt(i*2+1)    (* see 10.1 *)
INC(w[k].count)
t.Insert("John")  (* see 11 *)
```

### 9.3 Statement sequences

Statement sequences denote the sequence of actions specified by the component statements which are separated by semicolons.

StatementSequence = Statement {";" Statement}.

### 9.4 If statements

```
IfStatement =
  IF Expression THEN StatementSequence
  {ELSIF Expression THEN StatementSequence}
  [ELSE StatementSequence]
  END.
```

If statements specify the conditional execution of guarded statement sequences. The Boolean expression preceding a statement sequence is called its *guard*. The guards are evaluated in sequence of occurrence, until one evaluates to TRUE, whereafter its associated statement sequence is executed. If no guard is satisfied, the statement sequence following the symbol ELSE is executed, if there is one.

Example:

```
IF (ch >= "A") & (ch <= "Z") THEN ReadIdentifier
ELSIF (ch >= "0") & (ch <= "9") THEN ReadNumber
ELSIF (ch = " ") OR (ch = ',') THEN ReadString
ELSE SpecialCharacter
END
```

### 9.5 Case statements

Case statements specify the selection and execution of a statement sequence according to the value of an expression. First the case expression is evaluated, then that statement sequence is executed whose case label list contains the obtained value. The case expression must either be of an *integer type* that *includes* the types of all case labels, or both the case expression and the case labels must be of type CHAR. Case labels are constants, and no value must occur more than once. If the value of the expression does not occur as a label of any case, the statement sequence following the symbol ELSE is selected, if there is one, otherwise the program is aborted.

```
CaseStatement = CASE Expression OF Case {"|" Case} [ELSE StatementSequence] END.
Case           = [CaseLabelList ":" StatementSequence].
CaseLabelList = CaseLabels {"|" CaseLabels}.
CaseLabels    = ConstExpression [".." ConstExpression].
```

Example:

```
CASE ch OF
  "A" .. "Z": ReadIdentifier
|  "0" .. "9": ReadNumber
|  " ", ',': ReadString
ELSE SpecialCharacter
END
```

### 9.6 While statements

While statements specify the repeated execution of a statement sequence while the Boolean expression (its *guard*) yields TRUE. The guard is checked before every execution of the statement sequence.

WhileStatement = WHILE Expression DO StatementSequence END.

Examples:



```
WHILE i > 0 DO i := i DIV 2; k := k + 1 END
WHILE (t # NIL) & (t.key # i) DO t := t.left END
```

### 9.7 Repeat statements

A repeat statement specifies the repeated execution of a statement sequence until a condition specified by a Boolean expression is satisfied. The statement sequence is executed at least once.

RepeatStatement = REPEAT StatementSequence UNTIL Expression.

### 9.8 For statements

A for statement specifies the repeated execution of a statement sequence while a progression of values is assigned to an integer variable called the *control variable* of the for statement.

ForStatement = FOR ident ":" Expression TO Expression [BY ConstExpression] DO StatementSequence END.

The statement

```
FOR v := beg TO end BY step DO statements END
```

is equivalent to

```
temp := end; v := beg;
IF step > 0 THEN
  WHILE v <= temp DO statements; v := v + step END
ELSE
  WHILE v >= temp DO statements; v := v + step END
END
```

*temp* has the *same* type as *v*. *step* must be a nonzero constant expression. If *step* is not specified, it is assumed to be 1.

Examples:

```
FOR i := 0 TO 79 DO k := k + a[i] END
FOR i := 79 TO 1 BY -1 DO a[i] := a[i-1] END
```

### 9.9 Loop statements

A loop statement specifies the repeated execution of a statement sequence. It is terminated upon execution of an exit statement within that sequence (see 9.10).

LoopStatement = LOOP StatementSequence END.

Example:

```
LOOP
  ReadInt(i);
  IF i < 0 THEN EXIT END;
  WriteInt(i)
END
```

Loop statements are useful to express repetitions with several exit points or cases where the exit condition is in the middle of the repeated statement sequence.

### 9.10 Return and exit statements

A return statement indicates the termination of a procedure. It is denoted by the symbol RETURN, followed by an expression if the procedure is a function procedure. The type of the expression must be *assignment compatible* (see App. A) with the result type specified in the procedure heading (see Ch.10).

Function procedures require the presence of a return statement indicating the result value. In proper procedures, a return statement is implied by the end of the procedure body. Any explicit return statement therefore appears as an additional (probably exceptional) termination point.

An exit statement is denoted by the symbol EXIT. It specifies termination of the enclosing loop statement and continuation with the statement following that loop statement. Exit statements are contextually, although not syntactically associated with the loop statement which contains them.

### 9.11 With statements

With statements execute a statement sequence depending on the result of a type test and apply a type guard to every

occurrence of the tested variable within this statement sequence.

```
WithStatement = WITH Guard DO StatementSequence {"|" Guard DO StatementSequence}
              [ELSE StatementSequence] END.
Guard        = Qualident ":" Qualident.
```

If  $v$  is a variable parameter of record type or a pointer variable, and if it is of a static type  $T_0$ , the statement

```
WITH v: T1 DO S1 | v: T2 DO S2 ELSE S3 END
```

has the following meaning: if the dynamic type of  $v$  is  $T_1$ , then the statement sequence  $S_1$  is executed where  $v$  is regarded as if it had the static type  $T_1$ ; else if the dynamic type of  $v$  is  $T_2$ , then  $S_2$  is executed where  $v$  is regarded as if it had the static type  $T_2$ ; else  $S_3$  is executed.  $T_1$  and  $T_2$  must be extensions of  $T_0$ . If no type test is satisfied and if an else clause is missing the program is aborted.

Example:

```
WITH t: CenterTree DO i := t.width; c := t.subnode END
```

## 10. Procedure declarations

A procedure declaration consists of a *procedure heading* and a *procedure body*. The heading specifies the procedure identifier and the *formal parameters*. For type-bound procedures it also specifies the receiver parameter. The body contains declarations and statements. The procedure identifier is repeated at the end of the procedure declaration.

There are two kinds of procedures: *proper procedures* and *function procedures*. The latter are activated by a function designator as a constituent of an expression and yield a result that is an operand of the expression. Proper procedures are activated by a procedure call. A procedure is a function procedure if its formal parameters specify a result type. The body of a function procedure must contain a return statement which defines its result.

All constants, variables, types, and procedures declared within a procedure body are *local* to the procedure. Since procedures may be declared as local objects too, procedure declarations may be nested. The call of a procedure within its declaration implies recursive activation.

Objects declared in the environment of the procedure are also visible in those parts of the procedure in which they are not concealed by a locally declared object with the same name.

```
ProcedureDeclaration = ProcedureHeading ";" ProcedureBody ident.
ProcedureHeading    = PROCEDURE [Receiver] IdentDef [FormalParameters].
ProcedureBody       = DeclarationSequence [BEGIN StatementSequence] END.
DeclarationSequence =
  {CONST {ConstantDeclaration ";" } | TYPE {TypeDeclaration ";" } | VAR {VariableDeclaration ";" }
  {ProcedureDeclaration ";" | ForwardDeclaration ";" } }.
ForwardDeclaration  = PROCEDURE " ^ " [Receiver] IdentDef [FormalParameters].
```

If a procedure declaration specifies a *receiver* parameter, the procedure is considered to be bound to a type (see 10.2). A *forward declaration* serves to allow forward references to a procedure whose actual declaration appears later in the text. The formal parameter lists of the forward declaration and the actual declaration must *match* (see App. A).

### 10.1 Formal parameters

Formal parameters are identifiers declared in the formal parameter list of a procedure. They correspond to actual parameters specified in the procedure call. The correspondence between formal and actual parameters is established when the procedure is called. There are two kinds of parameters, *value* and *variable parameters*, indicated in the formal parameter list by the absence or presence of the keyword VAR. Value parameters are local variables to which the value of the corresponding actual parameter is assigned as an initial value. Variable parameters correspond to actual parameters that are variables, and they stand for these variables. The scope of a formal parameter extends from its declaration to the end of the procedure block in which it is declared. A function procedure without parameters must have an empty parameter list. It must be called by a function designator whose actual parameter list is empty too. The result type of a procedure can be neither a record nor an array.

```
FormalParameters = "(" [FPSection {";" FPSection}] ")" [";" Qualident].
FPSection        = [VAR] ident {";" ident} ":" Type.
```

Let  $T_f$  be the type of a formal parameter  $f$  (not an open array) and  $T_a$  the type of the corresponding actual parameter  $a$ . For variable parameters,  $T_a$  must be the *same* as  $T_f$ , or  $T_f$  must be a record type and  $T_a$  an extension of  $T_f$ . For value parameters,  $a$  must be *assignment compatible* with  $f$  (see App. A).

If  $T_f$  is an open array, then  $a$  must be *array compatible* with  $f$  (see App. A). The lengths of  $f$  are taken from  $a$ .

Examples of procedure declarations:

```
PROCEDURE ReadInt(VAR x: INTEGER);
  VAR i: INTEGER; ch: CHAR;
BEGIN i := 0; Read(ch);
  WHILE ("0" <= ch) & (ch <= "9") DO
    i := 10*i + (ORD(ch)-ORD("0")); Read(ch)
```

```

    END;
    x := i
END ReadInt

PROCEDURE WriteInt(x: INTEGER); (*0 <= x <100000*)
    VAR i: INTEGER; buf: ARRAY 5 OF INTEGER;
BEGIN i := 0;
    REPEAT buf[i] := x MOD 10; x := x DIV 10; INC(i) UNTIL x = 0;
    REPEAT DEC(i); Write(CHR(buf[i] + ORD("0"))) UNTIL i = 0
END WriteInt

PROCEDURE WriteString(s: ARRAY OF CHAR);
    VAR i: INTEGER;
BEGIN i := 0;
    WHILE (i < LEN(s)) & (s[i] # 0X) DO Write(s[i]); INC(i) END
END WriteString;

PROCEDURE log2(x: INTEGER): INTEGER;
    VAR y: INTEGER; (*assume x>0*)
BEGIN
    y := 0; WHILE x > 1 DO x := x DIV 2; INC(y) END;
    RETURN y
END log2

```

## 10.2 Type-bound procedures

Globally declared procedures may be associated with a record type declared in the same module. The procedures are said to be *bound* to the record type. The binding is expressed by the type of the *receiver* in the heading of a procedure declaration. The receiver may be either a variable parameter of record type  $T$  or a value parameter of type POINTER TO  $T$  (where  $T$  is a record type). The procedure is bound to the type  $T$  and is considered local to it.

```

ProcedureHeading = PROCEDURE [Receiver] IdentDef [FormalParameters].
Receiver          = "(" [VAR] ident ":" ident ")".

```

If a procedure  $P$  is bound to a type  $T_0$ , it is implicitly also bound to any type  $T_1$  which is an extension of  $T_0$ . However, a procedure  $P'$  (with the same name as  $P$ ) may be explicitly bound to  $T_1$  in which case it overrides the binding of  $P$ .  $P'$  is considered a *redefinition* of  $P$  for  $T_1$ . The formal parameters of  $P$  and  $P'$  must *match* (see App. A). If  $P$  and  $T_1$  are exported (see Chapter 4)  $P'$  must be exported too.

If  $v$  is a designator and  $P$  is a type-bound procedure, then  $v.P$  denotes that procedure  $P$  which is bound to the dynamic type of  $v$ . Note, that this may be a different procedure than the one bound to the static type of  $v$ .  $v$  is passed to  $P$ 's receiver according to the parameter passing rules specified in Chapter 10.1.

If  $r$  is a receiver parameter declared with type  $T$ ,  $r.P^\wedge$  denotes the (redefined) procedure  $P$  bound to the base type of  $T$ .

In a forward declaration of a type-bound procedure the receiver parameter must be of the *same* type as in the actual procedure declaration. The formal parameter lists of both declarations must *match* (App. A).

Examples:

```

PROCEDURE (t: Tree) Insert (node: Tree);
    VAR p, father: Tree;
BEGIN p := t;
    REPEAT father := p;
        IF node.key = p.key THEN RETURN END;
        IF node.key < p.key THEN p := p.left ELSE p := p.right END
    UNTIL p = NIL;
    IF node.key < father.key THEN father.left := node ELSE father.right := node END;
    node.left := NIL; node.right := NIL
END Insert;

PROCEDURE (t: CenterTree) Insert (node: Tree); (*redefinition*)
BEGIN
    WriteInt(node(CenterTree).width);
    t.Insert^ (node) (* calls the Insert procedure bound to Tree *)
END Insert;

```

## 10.3 Predeclared procedures

The following table lists the predeclared procedures. Some are generic procedures, i.e. they apply to several types of operands.  $v$  stands for a variable,  $x$  and  $n$  for expressions, and  $T$  for a type.

*Function procedures*

Name	Argument type	Result type	Function
ABS(x)	numeric type	type of x	absolute value
ASH(x, n)	x, n: integer type	LONGINT	arithmetic shift ( $x * 2^n$ )
CAP(x)	CHAR	CHAR	x is letter: corresponding capital letter
CHR(x)	integer type	CHAR	character with ordinal number x
ENTIER(x)	real type	LONGINT	largest integer not greater than x
LEN(v, n)	v: array; n: integer const.	LONGINT	length of v in dimension n (first dimension = 0)
LEN(v)	v: array	LONGINT	equivalent to LEN(v, 0)
LONG(x)	SHORTINT	INTEGER	identity
	INTEGER	LONGINT	
	REAL	LONGREAL	
MAX(T)	T = basic type	T	maximum value of type T
	T = SET	INTEGER	maximum element of a set
MIN(T)	T = basic type	T	minimum value of type T
	T = SET	INTEGER	0
ODD(x)	integer type	BOOLEAN	$x \text{ MOD } 2 = 1$
ORD(x)	CHAR	INTEGER	ordinal number of x
SHORT(x)	LONGINT	INTEGER	identity
	INTEGER	SHORTINT	identity
	LONGREAL	REAL	identity (truncation possible)
SIZE(T)	any type	integer type	number of bytes required by T

### Proper procedures

Name	Argument types	Function
ASSERT(x)	x: Boolean expression	terminate program execution if not x
ASSERT(x, n)	x: Boolean expression; n: integer constant	terminate program execution if not x
COPY(x, v)	x: character array, string; v: character array	$v := x$
DEC(v)	integer type	$v := v - 1$
DEC(v, n)	v, n: integer type	$v := v - n$
EXCL(v, x)	v: SET; x: integer type	$v := v - \{x\}$
HALT(n)	integer constant	terminate program execution
INC(v)	integer type	$v := v + 1$
INC(v, n)	v, n: integer type	$v := v + n$
INCL(v, x)	v: SET; x: integer type	$v := v + \{x\}$
NEW(v)	pointer to record or fixed array	allocate $v^{\wedge}$
NEW(v, x0, ..., xn)	v: pointer to open array; xi: integer type	allocate $v^{\wedge}$ with lengths $x0..xn$

COPY allows the assignment of a string or a character array containing a terminating 0X to another character array. If necessary, the assigned value is truncated to the target length minus one. The target will always contain 0X as a terminator. In ASSERT(x, n) and HALT(n), the interpretation of n is left to the underlying system implementation.

## 11. Modules

A module is a collection of declarations of constants, types, variables, and procedures, together with a sequence of statements for the purpose of assigning initial values to the variables. A module constitutes a text that is compilable as a unit.

Module	= MODULE ident ";" [ImportList] DeclarationSequence [BEGIN StatementSequence] END ident ".".
ImportList	= IMPORT Import {" , " Import} ";".
Import	= [ident ":"="] ident.

The import list specifies the names of the imported modules. If a module A is imported by a module M and A exports an identifier x, then x is referred to as A.x within M. If A is imported as B := A, the object x must be referenced as B.x. This allows short alias names in qualified identifiers. A module must not import itself. Identifiers that are to be exported (i.e. that are to be visible in client modules) must be marked by an export mark in their declaration (see Chapter 4).

The statement sequence following the symbol BEGIN is executed when the module is added to a system (loaded), which is done after the imported modules have been loaded. It follows that cyclic import of modules is illegal. Individual (parameterless and exported) procedures can be activated from the system, and these procedures serve as *commands* (see Appendix D1).

```
MODULE Trees; (* exports: Tree, Node, Insert, Search, Write, Init *)
IMPORT Texts, Oberon; (* exports read-only: Node.name *)
```

```
TYPE
  Tree* = POINTER TO Node;
  Node* = RECORD
    name-: POINTER TO ARRAY OF CHAR;
    left, right: Tree
  END;
```

```

VAR w: Texts.Writer;

PROCEDURE (t: Tree) Insert* (name: ARRAY OF CHAR);
  VAR p, father: Tree;
BEGIN p := t;
  REPEAT father := p;
    IF name = p.name^ THEN RETURN END;
    IF name < p.name^ THEN p := p.left ELSE p := p.right END
  UNTIL p = NIL;
  NEW(p); p.left := NIL; p.right := NIL; NEW(p.name, LEN(name)+1); COPY(name, p.name^);
  IF name < father.name^ THEN father.left := p ELSE father.right := p END
END Insert;

PROCEDURE (t: Tree) Search* (name: ARRAY OF CHAR): Tree;
  VAR p: Tree;
BEGIN p := t;
  WHILE (p # NIL) & (name # p.name^) DO
    IF name < p.name^ THEN p := p.left ELSE p := p.right END
  END;
  RETURN p
END Search;
PROCEDURE (t: Tree) Write*;
BEGIN
  IF t.left # NIL THEN t.left.Write END;
  Texts.WriteString(w, t.name^); Texts.WriteLine(w); Texts.Append(Oberon.Log, w.buf);
  IF t.right # NIL THEN t.right.Write END
END Write;

PROCEDURE Init* (t: Tree);
BEGIN NEW(t.name, 1); t.name[0] := 0X; t.left := NIL; t.right := NIL
END Init;

BEGIN Texts.OpenWriter(w)
END Trees.

```

## Appendix A: Definition of terms

<b>Integer types</b>	SHORTINT, INTEGER, LONGINT
<b>Real types</b>	REAL, LONGREAL
<b>Numeric types</b>	integer types, real types

### Same types

Two variables  $a$  and  $b$  with types  $Ta$  and  $Tb$  are of the *same* type if

1.  $Ta$  and  $Tb$  are both denoted by the same type identifier, or
2.  $Ta$  is declared to equal  $Tb$  in a type declaration of the form  $Ta = Tb$ , or
3.  $a$  and  $b$  appear in the same identifier list in a variable, record field, or formal parameter declaration and are not open arrays.

### Equal types

Two types  $Ta$  and  $Tb$  are *equal* if

1.  $Ta$  and  $Tb$  are the *same* type, or
2.  $Ta$  and  $Tb$  are open array types with *equal* element types, or
3.  $Ta$  and  $Tb$  are procedure types whose formal parameter lists *match*.

### Type inclusion

Numeric types *include* (the values of) smaller numeric types according to the following hierarchy:

LONGREAL >= REAL >= LONGINT >= INTEGER >= SHORTINT

### Type extension (base type)

Given a type declaration  $Tb = RECORD (Ta) \dots END$ ,  $Tb$  is a *direct extension* of  $Ta$ , and  $Ta$  is a *direct base type* of  $Tb$ . A type  $Tb$  is an *extension* of a type  $Ta$  ( $Ta$  is a *base type* of  $Tb$ ) if

1.  $Ta$  and  $Tb$  are the *same* types, or
2.  $Tb$  is a *direct extension* of an *extension* of  $Ta$

If  $Pa = POINTER TO Ta$  and  $Pb = POINTER TO Tb$ ,  $Pb$  is an *extension* of  $Pa$  ( $Pa$  is a *base type* of  $Pb$ ) if  $Tb$  is an *extension* of  $Ta$ .

### Assignment compatible

An expression  $e$  of type  $Te$  is *assignment compatible* with a variable  $v$  of type  $Tv$  if one of the following conditions hold:

1.  $Te$  and  $Tv$  are the *same* type;
2.  $Te$  and  $Tv$  are numeric types and  $Tv$  *includes*  $Te$ ;
3.  $Te$  and  $Tv$  are record types and  $Te$  is an *extension* of  $Tv$  and the dynamic type of  $v$  is  $Tv$ ;
4.  $Te$  and  $Tv$  are pointer types and  $Te$  is an *extension* of  $Tv$ ;
5.  $Tv$  is a pointer or a procedure type and  $e$  is NIL;
6.  $Tv$  is ARRAY  $n$  OF CHAR,  $e$  is a string constant with  $m$  characters, and  $m < n$ ;
7.  $Tv$  is a procedure type and  $e$  is the name of a procedure whose formal parameters *match* those of  $Tv$ .

### Array compatible

An actual parameter  $a$  of type  $Ta$  is *array compatible* with a formal parameter  $f$  of type  $Tf$  if

1.  $Tf$  and  $Ta$  are the *same* type, or
2.  $Tf$  is an open array,  $Ta$  is any array, and their element types are *array compatible*, or
3.  $Tf$  is ARRAY OF CHAR and  $a$  is a string.

### Expression compatible

For a given operator, the types of its operands are *expression compatible* if they conform to the following table (which shows also the result type of the expression). Character arrays that are to be compared must contain 0X as a terminator. Type T1 must be an extension of type T0:

<i>operator</i>	<i>first operand</i>	<i>second operand</i>	<i>result type</i>
+ - *	<i>numeric</i>	<i>numeric</i>	smallest <i>numeric</i> type including both
operands			
/	<i>numeric</i>	<i>numeric</i>	smallest <i>real</i> type including both operands
+ - * /	SET	SET	SET
DIV MOD	<i>integer</i>	<i>integer</i>	smallest <i>integer</i> type including both
operands			
OR & ~	BOOLEAN	BOOLEAN	BOOLEAN
= # < <= > >=	<i>numeric</i>	<i>numeric</i>	BOOLEAN
	CHAR	CHAR	BOOLEAN
	character array, string	character array, string	BOOLEAN
= #	BOOLEAN	BOOLEAN	BOOLEAN
	SET	SET	BOOLEAN
	NIL, pointer type T0 or T1	NIL, pointer type T0 or T1	BOOLEAN

IN	procedure type T, NIL	procedure type T, NIL	BOOLEAN
IS	<i>integer</i>	SET	BOOLEAN
	type T0	type T1	BOOLEAN

**Matching formal parameter lists**

Two formal parameter lists *match* if

1. they have the same number of parameters, and
2. they have either the *same* function result type or none, and
3. parameters at corresponding positions have *equal* types, and
4. parameters at corresponding positions are both either value or variable parameters.

## Appendix B: Syntax of Oberon-2

Module	=	MODULE ident ";" [ImportList] DeclSeq [BEGIN StatementSeq] END ident ".".
ImportList	=	IMPORT [ident ":="] ident {" ," [ident ":="] ident} ";".
DeclSeq	=	{ CONST {ConstDecl ";" }   TYPE {TypeDecl ";" }   VAR {VarDecl ";" } {ProcDecl ";"   ForwardDecl ";" }.
ConstDecl	=	IdentDef "=" ConstExpr.
TypeDecl	=	IdentDef "=" Type.
VarDecl	=	IdentList ":" Type.
ProcDecl	=	PROCEDURE [Receiver] IdentDef [FormalPars] ";" DeclSeq [BEGIN StatementSeq] END ident.
ForwardDecl	=	PROCEDURE "^" [Receiver] IdentDef [FormalPars].
FormalPars	=	"(" [FPSection {";" FPSection}] ")" [":" Qualident].
FPSection	=	[VAR] ident {" ," ident} ":" Type.
Receiver	=	"(" [VAR] ident ":" ident ")".
Type	=	Qualident   ARRAY [ConstExpr {" ," ConstExpr}] OF Type   RECORD [{"Qualident"}] FieldList {" ," FieldList} END   POINTER TO Type   PROCEDURE [FormalPars].
FieldList	=	[IdentList ":" Type].
StatementSeq	=	Statement {";" Statement}.
Statement	=	[ Designator ":=" Expr   Designator [{" [ExprList] "}"]   IF Expr THEN StatementSeq {ELSIF Expr THEN StatementSeq} [ELSE StatementSeq] END   CASE Expr OF Case {" " Case} [ELSE StatementSeq] END   WHILE Expr DO StatementSeq END   REPEAT StatementSeq UNTIL Expr   FOR ident ":=" Expr TO Expr [BY ConstExpr] DO StatementSeq END   LOOP StatementSeq END   WITH Guard DO StatementSeq {" " Guard DO StatementSeq} [ELSE StatementSeq] END   EXIT   RETURN [Expr] ].
Case	=	[CaseLabels {" ," CaseLabels} ":" StatementSeq].
CaseLabels	=	ConstExpr [{".." ConstExpr}].
Guard	=	Qualident ":" Qualident.
ConstExpr	=	Expr.
Expr	=	SimpleExpr [Relation SimpleExpr].
SimpleExpr	=	["+ "   "- "] Term {AddOp Term}.
Term	=	Factor {MulOp Factor}.
Factor	=	Designator [{" [ExprList] "}"]   number   character   string   NIL   Set   "(" Expr ")"   "~ " Factor.
Set	=	"{" [Element {" ," Element}] "}".
Element	=	Expr [{".." Expr}].
Relation	=	"="   "# "   "<"   "<="   ">"   ">="   IN   IS.
AddOp	=	"+"   "-"   OR.
MulOp	=	"*"   "/"   DIV   MOD   "&".
Designator	=	Qualident {" ." ident   "[" ExprList "]"   "^ "   "(" Qualident ")" }.
ExprList	=	Expr {" ," Expr}.
IdentList	=	IdentDef {" ," IdentDef}.
Qualident	=	[ident "."] ident.
IdentDef	=	ident [{" * "   "- " }].



## Appendix C: The module SYSTEM

The module SYSTEM contains certain types and procedures that are necessary to implement *low-level* operations particular to a given computer and/or implementation. These include for example facilities for accessing devices that are controlled by the computer, and facilities to break the type compatibility rules otherwise imposed by the language definition. It is strongly recommended to restrict their use to specific modules (called *low-level* modules). Such modules are inherently non-portable, but easily recognized due to the identifier SYSTEM appearing in their import list. The following specifications hold for the implementation of Oberon-2 on the Ceres computer.

Module SYSTEM exports a type BYTE with the following characteristics: Variables of type CHAR or SHORTINT can be assigned to variables of type BYTE. If a formal variable parameter is of type ARRAY OF BYTE then the corresponding actual parameter may be of any type.

Another type exported by module SYSTEM is the type PTR. Variables of any pointer type may be assigned to variables of type PTR. If a formal variable parameter is of type PTR, the actual parameter may be of any pointer type.

The procedures contained in module SYSTEM are listed in the following tables. Most of them correspond to single instructions compiled as in-line code. For details, the reader is referred to the processor manual. *v* stands for a variable, *x*, *y*, *a*, and *n* for expressions, and *T* for a type.

### Function procedures

Name	Argument types	Result type	Function
ADR( <i>v</i> )	any	LONGINT	address of variable <i>v</i>
BIT( <i>a</i> , <i>n</i> )	<i>a</i> : LONGINT <i>n</i> : <i>integer</i>	BOOLEAN	bit <i>n</i> of Mem[ <i>a</i> ]
CC( <i>n</i> )	<i>integer</i> constant	BOOLEAN	condition <i>n</i> ( $0 \leq n \leq 15$ )
LSH( <i>x</i> , <i>n</i> )	<i>x</i> : <i>integer</i> , CHAR, BYTE <i>n</i> : <i>integer</i>	type of <i>x</i>	logical shift
ROT( <i>x</i> , <i>n</i> )	<i>x</i> : <i>integer</i> , CHAR, BYTE <i>n</i> : <i>integer</i>	type of <i>x</i>	rotation
VAL( <i>T</i> , <i>x</i> )	<i>T</i> , <i>x</i> : any type	<i>T</i>	<i>x</i> interpreted as of type <i>T</i>

### Proper procedures

Name	Argument types	Function
GET( <i>a</i> , <i>v</i> )	<i>a</i> : LONGINT; <i>v</i> : any basic type, pointer, procedure type	$v := \text{Mem}[a]$
PUT( <i>a</i> , <i>x</i> )	<i>a</i> : LONGINT; <i>x</i> : any basic type, pointer, procedure type	$\text{Mem}[a] := x$
GETREG( <i>n</i> , <i>v</i> )	<i>n</i> : <i>integer</i> constant; <i>v</i> : any basic type, pointer, procedure type	$v := \text{Register } n$
PUTREG( <i>n</i> , <i>x</i> )	<i>n</i> : <i>integer</i> constant; <i>x</i> : any basic type, pointer, procedure type	$\text{Register } n := x$
MOVE( <i>a0</i> , <i>a1</i> , <i>n</i> )	<i>a0</i> , <i>a1</i> : LONGINT; <i>n</i> : <i>integer</i>	$\text{Mem}[a1.. a1+n-1] := \text{Mem}[a0.. a0+n-1]$
NEW( <i>v</i> , <i>n</i> )	<i>v</i> : any pointer; <i>n</i> : <i>integer</i>	allocate storage block of <i>n</i> bytes assign its address to <i>v</i>

## Appendix D: The Oberon Environment

Oberon-2 programs usually run in an environment that provides *command activation*, *garbage collection*, *dynamic loading* of modules, and certain *run time data structures*. Although not part of the language, this environment contributes to the power of Oberon-2 and is to some degree implied by the language definition. Appendix D describes the essential features of a typical Oberon environment and provides implementation hints. More details can be found in [1], [2], and [3].

### D1. Commands

A command is any parameterless procedure  $P$  that is exported from a module  $M$ . It is denoted by  $M.P$  and can be activated under this name from the shell of the operating system. In Oberon, a user invokes commands instead of programs or modules. This gives him a finer grain of control and allows modules with multiple entry points. When a command  $M.P$  is invoked, the module  $M$  is dynamically loaded unless it is already in memory (see D2) and the procedure  $P$  is executed. When  $P$  terminates,  $M$  remains loaded. All global variables and data structures that can be reached from global pointer variables in  $M$  retain their values. When  $P$  (or another command of  $M$ ) is invoked again, it may continue to use these values.

The following module demonstrates the use of commands. It implements an abstract data structure *Counter* that encapsulates a counter variable and provides commands to increment and print its value.

```
MODULE Counter;
  IMPORT Texts, Oberon;

  VAR
    counter: LONGINT;
    w: Texts.Writer;

  PROCEDURE Add*; (* takes a numeric argument from the command line *)
    VAR s: Texts.Scanner;
  BEGIN
    Texts.OpenScanner(s, Oberon.Par.text, Oberon.Par.pos);
    Texts.Scan(s);
    IF s.class = Texts.Int THEN INC(counter, s.i) END
  END Add;

  PROCEDURE Write*;
  BEGIN
    Texts.WriteInt(w, counter, 5); Texts.WriteLine(w);
    Texts.Append(Oberon.Log, w.buf)
  END Write;

  BEGIN counter := 0; Texts.OpenWriter(w)
  END Counter.
```

The user may execute the following two commands:

```
Counter.Add n    adds the value n to the variable counter
Counter.Write   writes the current value of counter to the screen
```

Since commands are parameterless they have to get their arguments from the operating system. In general, commands are free to take arguments from everywhere (e.g. from the text following the command, from the most recent selection, or from a marked viewer). The command *Add* uses a scanner (a data type provided by the Oberon system) to read the value that follows it on the command line.

When *Counter.Add* is invoked for the first time, the module *Counter* is loaded and its body is executed. Every call of *Counter.Add n* increments the variable *counter* by *n*. Every call of *Counter.Write* writes the current value of *counter* to the screen.

Since a module remains loaded after the execution of its commands, there must be an explicit way to unload it (e.g. when the user wants to substitute the loaded version by a recompiled version.) The Oberon system provides a command to do that.

### D2. Dynamic Loading of Modules

A loaded module may invoke a command of a still unloaded module by specifying its name as a string. The specified module is then dynamically loaded and the designated command is executed. Dynamic loading allows the user to start a program as a small set of basic modules and to extend it by adding further modules at run time as the need becomes evident.

A module  $M_0$  may cause the dynamic loading of a module  $M_1$  without importing it.  $M_1$  may of course import and use  $M_0$ , but  $M_0$  need not know about the existence of  $M_1$ .  $M_1$  can be a module that is designed and implemented long after  $M_0$ .

### D3. Garbage Collection

In Oberon-2, the predeclared procedure NEW is used to allocate data blocks in free memory. There is, however, no way to explicitly dispose an allocated block. Rather, the Oberon environment uses a *garbage collector* to find the blocks that are not used any more and to make them available for allocation again. A block is in use as long as it can be reached from a global pointer variable via a pointer chain. Cutting this chain (e.g., setting a pointer to NIL) makes the block collectable.

A garbage collector frees a programmer from the non-trivial task of deallocating data structures correctly and thus helps to avoid errors. However, it requires information about dynamic data at run time (see D5).

#### D4. Browser

The interface of a module (the declaration of the exported objects) is extracted from the module by a so-called *browser* which is a separate tool of the Oberon environment. For example, the browser produces the following interface of the module *Trees* from Ch. 11.

```
DEFINITION Trees;
TYPE
  Tree = POINTER TO Node;
  Node = RECORD
    name: POINTER TO ARRAY OF CHAR;
    PROCEDURE (t: Tree) Insert (name: ARRAY OF CHAR);
    PROCEDURE (t: Tree) Search (name: ARRAY OF CHAR): Tree;
    PROCEDURE (t: Tree) Write;
  END;
PROCEDURE Init (VAR t: Tree);
END Trees.
```

For a record type, the browser also collects all procedures bound to this type and shows their declaration in the record type declaration.

#### D5. Run Time Data Structures

Certain information about records has to be available at run time: The dynamic type of records is needed for type tests and type guards. A table with the addresses of the procedures bound to a record is needed for calling them. Finally, the garbage collector needs information about the location of pointers in dynamically allocated records. All that information is stored in so-called *type descriptors* of which there is one for every record type at run time. The following paragraphs show a possible implementation of type descriptors.

The dynamic type of a record corresponds to the address of its type descriptor. For dynamically allocated records this address is stored in a so-called *type tag* which precedes the actual record data and which is invisible for the programmer. If *t* is a variable of type *CenterTree* (see example in Ch. 6) Figure D5.1 shows one possible implementation of the run time data structures.

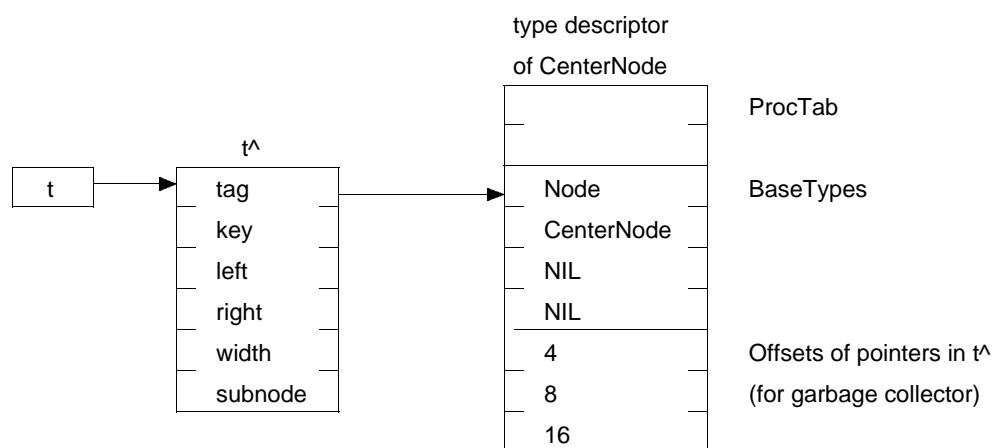

Fig. D5.1 A variable *t* of type *CenterTree*, the record *t^* it points to, and its type descriptor

Since both the table of procedure addresses and the table of pointer offsets must have a fixed offset from the type descriptor address, and since both may grow when the type is extended and further procedures and pointers are added, the tables are located at the opposite ends of the type descriptor and grow in different directions.

A type-bound procedure *t.P* is called as *t^.tag^.ProcTab[IndexP]*. The procedure table index of every type-bound procedure is known at compile time. A type test *v IS T* is translated into *v^.tag^.BaseTypes[ExtensionLevelT] = TypeDescrAdrT*. Both the extension level of a record type and the address of its type descriptor are known at compile time. For example, the extension level of *Node* is 0 (it has no base type), and the extension level of *CenterNode* is 1.

[1] N.Wirth, J.Gutknecht: The Oberon System. Software Practice and Experience 19, 9, Sept. 1989

[2] M.Reiser: The Oberon System. User Guide and Programming Manual. Addison-Wesley, 1991

